

Study on the sliding mode control method for the active suspension system

Tuan Anh Nguyen*

Automotive Engineering Department, Thuyloi University, Hanoi, Vietnam

ABSTRACT

When the vehicle moves, the bump on the road surface is the main factor affecting the vehicle's stability. It produces non-cyclic oscillations and causes a feeling of discomfort and fatigue for passengers. The suspension system of the vehicle is used to regulate and reduce these negative effects. In order to improve vehicle stability and comfort, the active suspension is used to replace the conventional passive suspension system. There are many methods to control the suspension system, each with its advantages and disadvantages. This article focuses on the introduction and establishment of the sliding mode controller for the active suspension system. The results of the study show that when the vehicle is equipped with an active suspension system that is controlled by a sliding mode controller, the values of displacement and acceleration of the sprung mass are significantly reduced. Therefore, the vehicle's stability and comfort are also greatly improved. Besides, the sliding mode controller is very stable to the change of the impact factors. However, this method is more difficult and complex than the use of conventional linear methods.

Keywords: Active suspension system, Sliding mode control, Comfortable, Sprung mass.

OPEN ACCESS

Received: February 16, 2020

Revised: April 26, 2020

Accepted: May 8, 2021

Corresponding Author:

Tuan Anh Nguyen

anhngtu@tlu.edu.vn

 **Copyright:** The Author(s). This is an open access article distributed under the terms of the [Creative Commons Attribution License \(CC BY 4.0\)](https://creativecommons.org/licenses/by/4.0/), which permits unrestricted distribution provided the original author and source are cited.

Publisher:

[Chaoyang University of Technology](https://www.chaoyang.edu.cn/)

ISSN: 1727-2394 (Print)

ISSN: 1727-7841 (Online)

1. INTRODUCTION

The suspension system of the vehicle is very important. The suspension supports maintaining the vehicle's stability and smoothness while moving on the road. The suspension system separates the vehicle into two separate parts, including the sprung mass and the unsprung mass. If the displacement and acceleration of the sprung mass are small, the vehicle will be more stable. Otherwise, if these values are too large, passengers will feel uncomfortable and the smoothness of the vehicle will be lost.

Today, there is a lot of methods to improve the stability and comfort of the suspension system. Almost luxury and modern vehicles can use the active suspension system, the semi-active suspension system instead of only using the conventional passive suspension system. Therefore, the safety and comfort of the vehicle have also been significantly improved. This study focuses on the control, simulation, and evaluation of the active suspension system compared to the conventional passive suspension system.

The active suspension system is equipped with an actuator at each wheel (Marcu et al., 2017). This unit is a hydraulic piston that is controlled by a controller based on the signals collected from the sensors. The hydraulic piston will generate the corresponding force F_S on the sprung mass and unsprung mass of the vehicle. The magnitude of the generated force F_S was consistent with the state of the vehicle's oscillation at that time. Therefore, the stability and comfort of the vehicle can be significantly improved.

There are many studies on the vibration and oscillation of the suspension system using on the vehicle has been done during the last time. Konieczny and Burdzik (2017) introduced suspension system models, including the passive suspension system, the active suspension system, and the semi-active suspension system. This assessment was also commented on by Xue et al. (2011) in their paper. The study of Riduan et al. (2018) also had an overall evaluation of the active suspension system which is found in today's

modern vehicles. Most of kind of the active suspension system are equipped with a hydraulic actuator. This actuator is controlled by a servo valve based on the voltage signal supplied by the controller (Shafie et al., 2015). In Tamburrano et al. (2019), they introduced and specifically reviewed the electro-hydraulic servo valve which is equipped with the active suspension system.

Many methods are used to control the operation of the active suspension system. In Avesh and Srivastava (2012), they proposed a plan to use the PID (Proportional – Integral – Derivative) controller to evaluate the efficiency of the suspension system. This method is quite simple. However, the selection of parameters to optimize the system is very complex. Besides, this controller is just SISO (Single Input – Single Output), so it cannot meet all the requirements for control signals. In order to improve the suspension system’s efficiency, an LQR (Linear – Quadratic Regulator) controller was used (Maurya and Bhargal, 2018; Nagarkar et al., 2011; Bello et al., 2015). Also, Pang et al. have integrated Gaussian filters into their controllers. The LQR controller becomes the LQG controller with the same features (Pang et al., 2017). In Anh (2020), he compared the difference between 2 linear controllers, PID and LQR. Although the LQR controller is MIMO (Multiple Input – Multiple Output), the control parameters are not close to the desired threshold. Therefore, many studies have proposed to use nonlinear control methods and intelligent control of the active suspension system.

The method of using the sliding mode controller is appreciated. This controller helps the output signal always track with the desired threshold value (Wei and Su, 2020; Bai and Guo, 2018; Deshpande et al., 2012). However, this is a nonlinear control method, so the design and simulation processes are also quite complicated. Besides, many other

intelligent control methods are also used such as: H_∞ control (Rizvi et al., 2018), robust control (Kaleemullah et al., 2019; Li et al., 2019), adaptive control (Soleymani et al., 2012; Na et al., 2020), fuzzy control (Lin et al., 2009; Lin et al., 2019; Palanisamy and Karuppan, 2016; Turkkan and Yagiz, 2013; Sun et al., 2013), network control (Fu et al., 2017; Youness and Lobusov, 2019; Liu et al., 2019), etc. Also, integrated controllers with high performance were introduced (Na et al., 2020; Lee et al., 2020; Williams and Haddad, 1997; Soh et al., 2018; Elmadany, 2012; Xiao et al., 2009; Sam et al., 2007). In general, the control methods for the active suspension system are very effective. This system makes the vehicle more stable and safe, ensuring comfort for passengers. This article focuses on the introduction, design, and evaluation of the active suspension system which is controlled by a sliding mode controller.

2. MATERIALS AND METHODS

2.1 Dynamic Vehicle

In studies of controlling mechatronic systems in the vehicle, the quarter model is commonly used. The schematic of the model is shown in Fig. 1.

Equations describing the vehicle's oscillation is given as follows:

$$M\ddot{z} = F_K + F_C + F_S \tag{1}$$

$$m\ddot{\xi} = F_{KT} - F_K - F_C - F_S \tag{2}$$

Where:

$$F_K = K(\xi - z) \tag{3}$$

$$F_C = C(\dot{\xi} - \dot{z}) \tag{4}$$

$$F_{KT} = K_T(h - \xi) \tag{5}$$

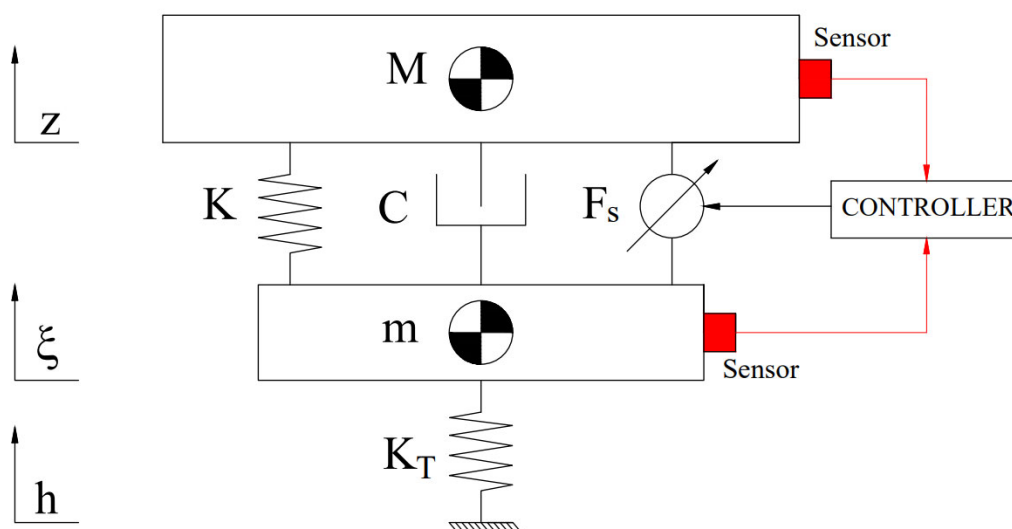

Fig. 1. Quarter model of the vehicle

2.2 Design the Sliding Mode Controller

The sliding mode control method is a nonlinear control method with the SISO system. Compared with the linear control methods such as PID, LQR, LQG, ... the sliding mode control method helps the system to be more stable and suitable against the changes of external influences. However, the sliding mode controller design process is also very complicated.

Consider a nonlinear system SISO with an instability. Let $u(t)$ be the input signal and $y(t)$ be the output signal. This system is described by the equation below:

$$\frac{d^n y}{dt^n} = f\left(y, \frac{dy}{dt}, \dots, \frac{d^{n-1}y}{dt^{n-1}}\right) + u \tag{6}$$

Let: $\frac{d^{k-1}y}{dt^{k-1}} = x_k; k = \overline{1, n}$ (7)

Equation (6) can be rewritten as follows:

$$\begin{cases} \frac{dx_k}{dt} = x_{k+1}, 1 \leq k \leq n-1 \\ \frac{dx_n}{dt} = f(x) + u \end{cases} \quad \underline{x} = \begin{pmatrix} x_1 \\ \vdots \\ x_n \end{pmatrix} \tag{8}$$

When the function is instability, the state feedback controller should be designed so that the closed system is asymptomatic stable at the origin. Let $e(t)$ be the signal of deviation:

$$e(t) = y_d(t) - y(t) \tag{9}$$

Consider the smooth function $s(e)$ of the deviation $e(t)$:

$$s(e) = s\left(e, \frac{de}{dt}, \dots, \frac{d^{n-1}e}{dt^{n-1}}\right) \tag{10}$$

The differential equation $s(e) = 0$ needs root $e(t)$ that satisfies the following condition:

$$\lim_{t \rightarrow \infty} x_{k+1} = \lim_{t \rightarrow \infty} \frac{d^k y}{dt^k} = -\lim_{t \rightarrow \infty} \frac{d^k e}{dt^k} = 0 \tag{11}$$

Then, the function $s(e)$ is the sliding surface. Usually, the constant parameter sliding surface is the most commonly used type:

$$s(e) = a_0 e + a_1 \frac{de}{dt} + \dots + a_{n-2} \frac{d^{n-2}e}{dt^{n-2}} + \frac{d^{n-1}e}{dt^{n-1}} \tag{12}$$

In which, the coefficients are real numbers. Then, the characteristic polynomial $p(\lambda)$ must be the Hurwitz polynomial:

$$p(\lambda) = a_0 + a_1 \lambda + \dots + a_{n-2} \lambda^{n-2} + \lambda^{n-1} \tag{13}$$

After the sliding surface has been determined, the sliding mode controller should also be designed. This controller must make $s(e) \rightarrow 0$. This is called the sliding condition. The schematic of the sliding mode controller is shown in Fig. 2.

With the dynamic model as shown in Fig. 1, the sliding surface is designed as follows:

$$s(e) = \xi(t) + a_1 e(t) \tag{14}$$

The algebraic expression of the sliding mode controller takes the form:

$$u = F_s = M \left[-\frac{K}{M} \xi - \frac{C}{M} \xi + \frac{K}{M} z + \frac{C}{M} \dot{z} + \frac{d}{dt} \xi + a_1 \xi(t) + A \operatorname{sgn}(s(e)) \right] \tag{15}$$

With the designed sliding mode controller, the results of the simulation are given in section 3.

3. RESULTS AND DISCUSSION

3.1 Simulation Conditions

This study focuses on simulating the oscillation of the vehicle using the quarter model. The specifications of the vehicle are shown in Table 1.

The bump on the road is the direct cause of displacement and oscillation of the sprung mass. There are many types of bump on the road that can appear when a vehicle moves on the road. In the studies about simulation and control, there are some commonly used types such as sine wave, step, ramp, ... The sine wave is typical stimulation for simulation problems. Because it changes cyclically over time, the values of acceleration and displacement of the sprung mass can be calculated stably. However, when the vehicle moves on the road, the random stimulation from the road surface will appear. They continuously change and do not follow any rules. This is the stimulating condition consistent with reality. Therefore, the simulation process should be done in these two cases.

Case 1: Sine wave type (Fig. 3). This oscillation changes cyclic according to the sine function rule. It is often used in studies of control algorithms.

$$h = 50 \sin 5t \text{ (mm)} \tag{16}$$

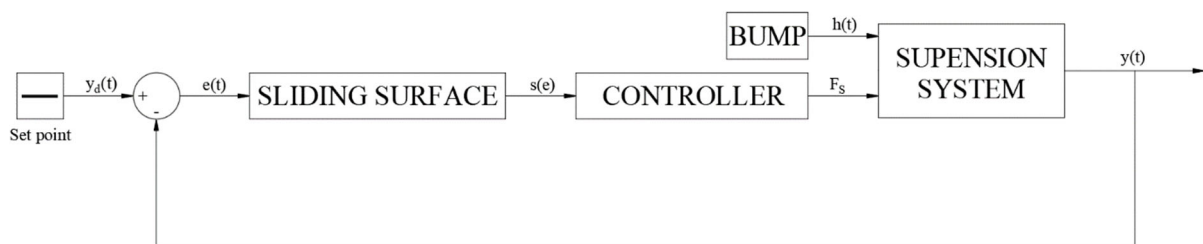

Fig. 2. The schematic of the sliding mode control method

Table 1. Specifications of the vehicle

Description	Symbol	Value	Unit
Sprung mass	M	405	kg
Unsprung mass	m	38	kg
Coefficient of spring	K	28500	N/m
Coefficient of damper	C	2150	Ns/m
Coefficient of tire	K_T	140000	N/m

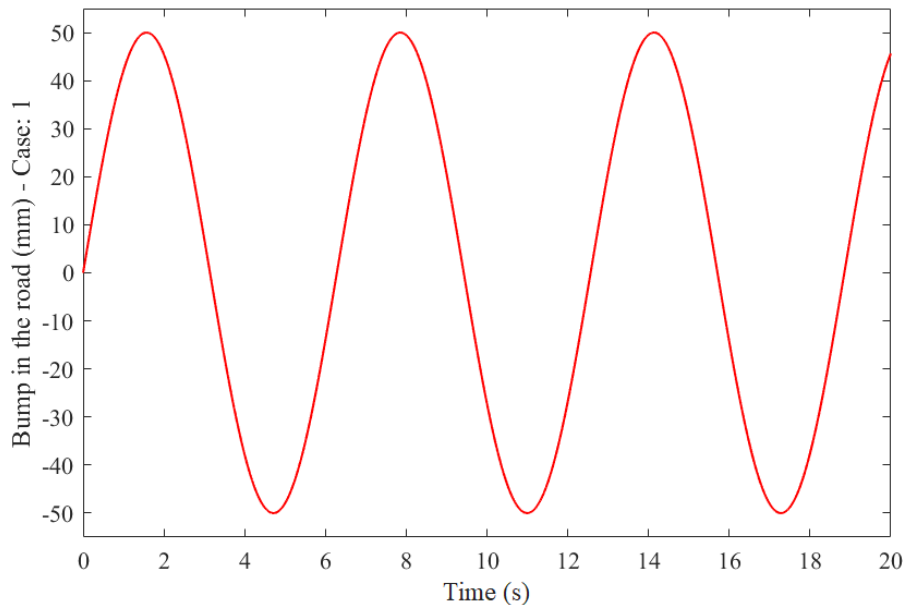

Fig. 3. Bump on the road (Case: 1)

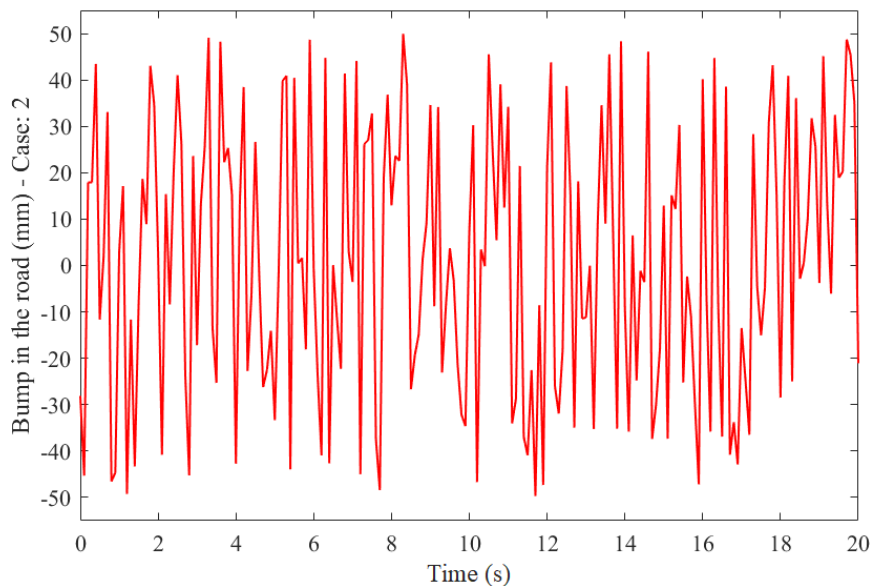

Fig. 4. Bump on the road (Case: 2)

Case 2: Random type (Fig. 4). This oscillation varies randomly and does not depend on other factors. This is the kind of bump that can be encountered while vehicles move on the road.

$$h = 50\text{Rand}(0.1t) \text{ (mm)} \quad (17)$$

3.2 Results

The simulation process is performed in the 2 cases above.

Case 1: Sine function

The graph of Fig. 5 shows the displacement of the sprung mass of the vehicle when using the active suspension system

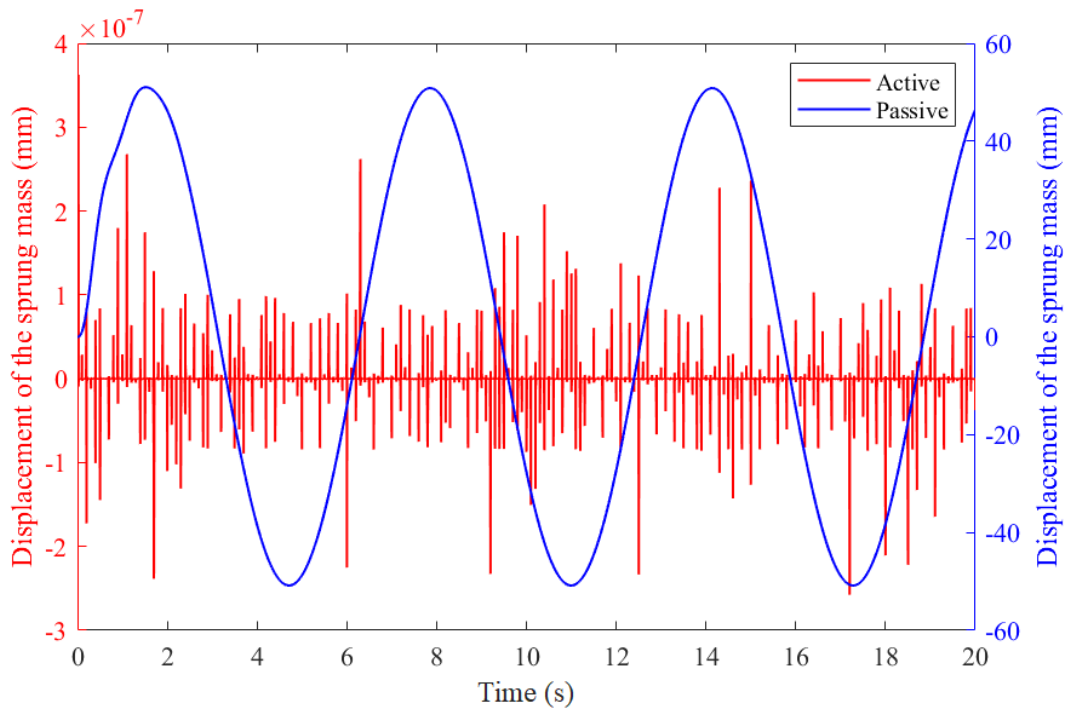

Fig. 5. Displacement of the sprung mass

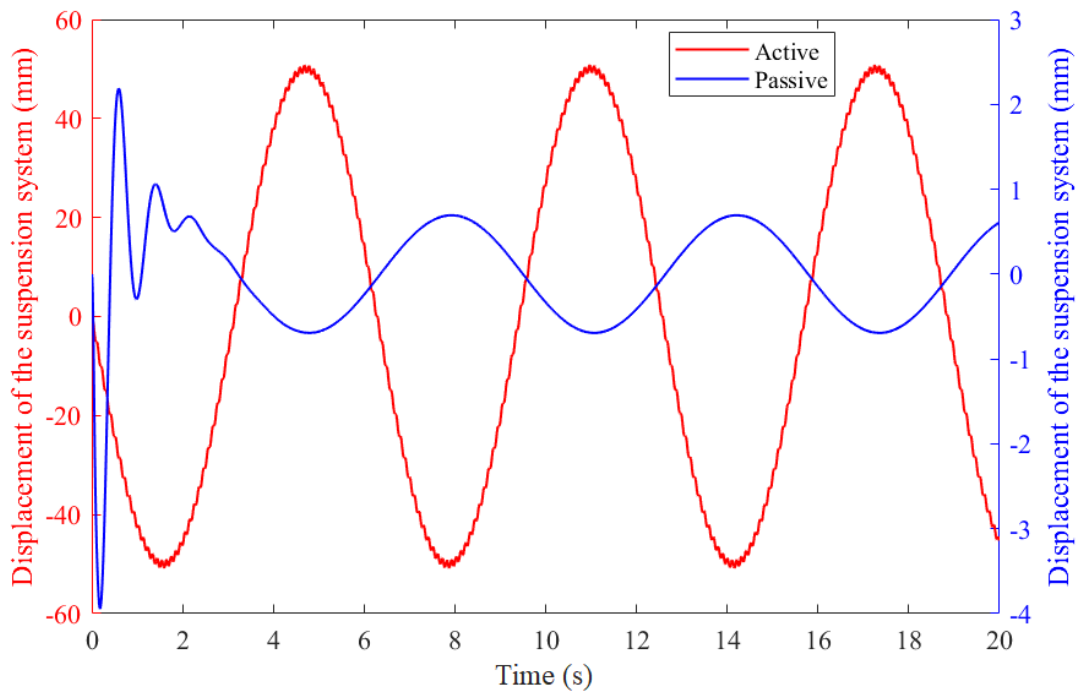

Fig. 6. Displacement of the suspension system

and the passive suspension system. The value of displacement of the sprung mass when the vehicle is equipped with the active suspension system has been significantly improved. The maximum amplitude of oscillation is less than 3×10^{-7} mm, the body of the vehicle is almost unchanged. In contrast, the displacement of the

sprung mass when using the passive suspension system is quite large, around 50 mm.

Since the displacement of the sprung mass of the vehicle when equipped with the active suspension is very small (almost unchanged), the value of the displacement of the suspension system will have to be increased as shown in Fig. 6. The suspension system (active suspension) will oscillate

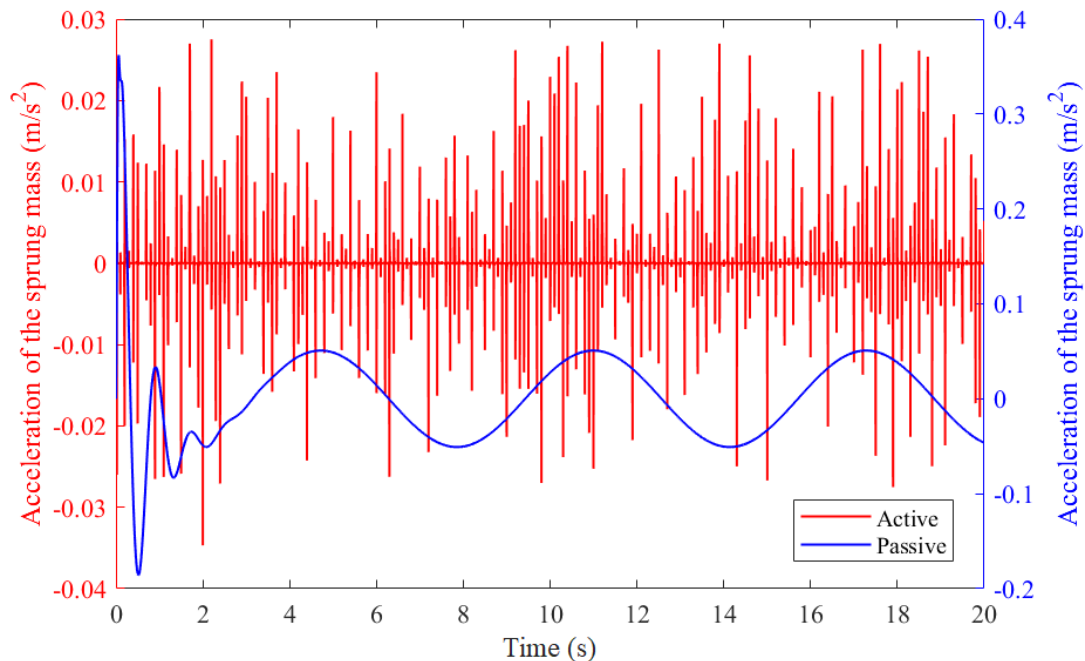

Fig. 7. Acceleration of the sprung mass

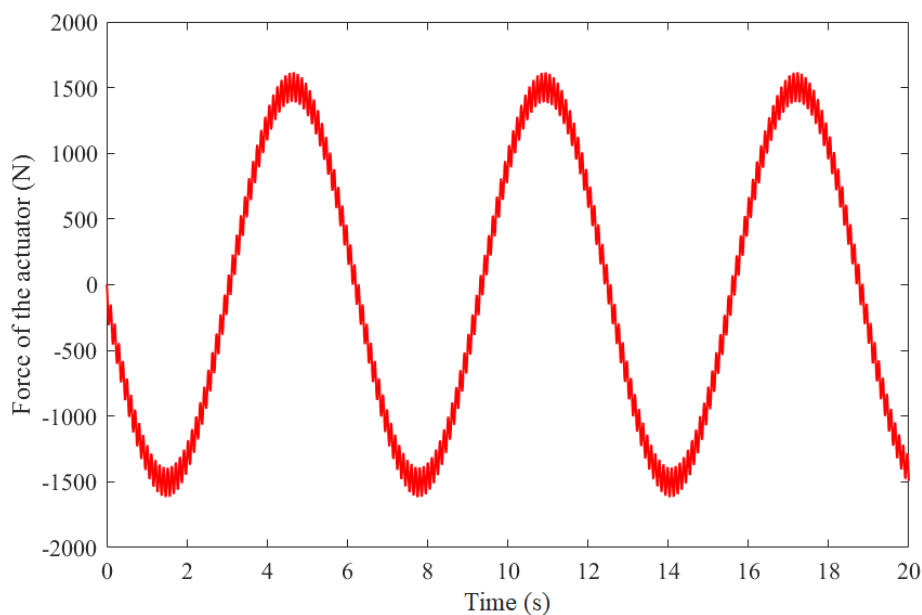

Fig. 8. Force of the actuator

with an amplitude that approximates that of the bump on the road, about 50 mm. Meanwhile, the displacement of the suspension system when equipped with the passive suspension system will be smaller.

The acceleration of the sprung mass is a very important value. This value is used to evaluate the comfort of the vehicle while moving. If this value is too large, the vehicle's comfort will be reduced. The graph in Fig. 7 shows the change of acceleration when the vehicle uses the active suspension system and the conventional passive suspension system. If the vehicle is equipped with the active suspension

system, the acceleration's maximum value of the sprung mass is only about 0.035 m/s^2 . However, the acceleration of the sprung mass when the vehicle is equipped with the passive suspension system is great. This value reaches maximum at 0.34 m/s^2 and stable oscillate around 0.05 m/s^2 . Therefore, if the car uses the active suspension system, it will be possible to improve comfort and stability when moving.

The force generated by the actuator tracks the trajectory very well. In case 1, this value is not too large (Fig. 8), The change is continuous and stable.

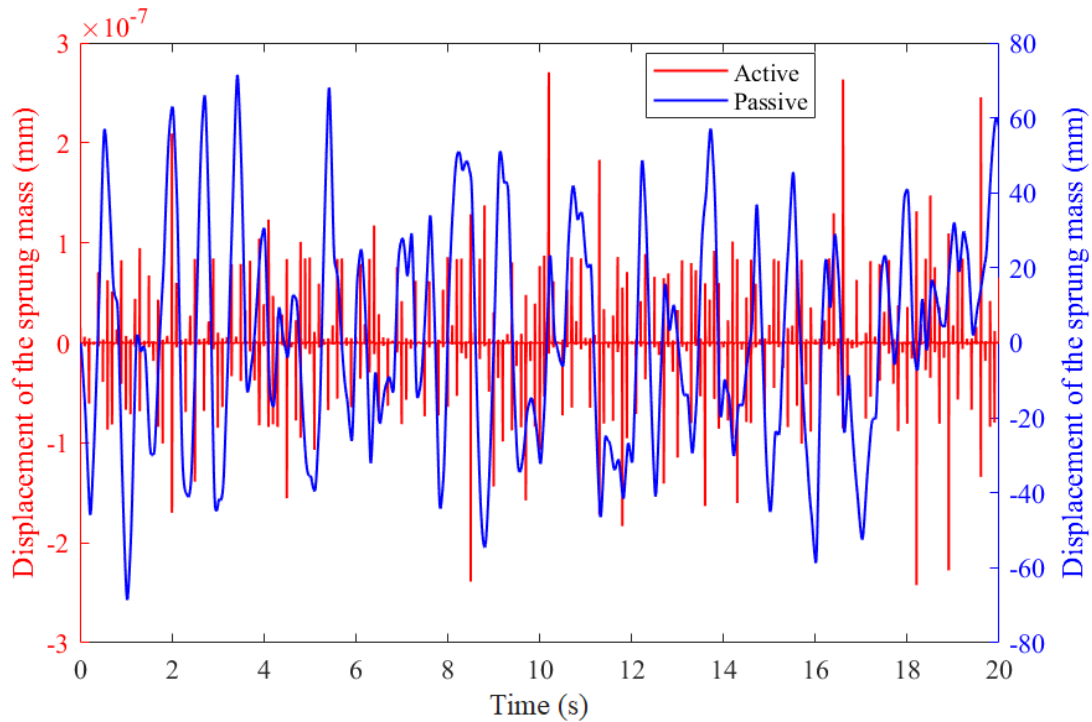

Fig. 9. Displacement of the sprung mass

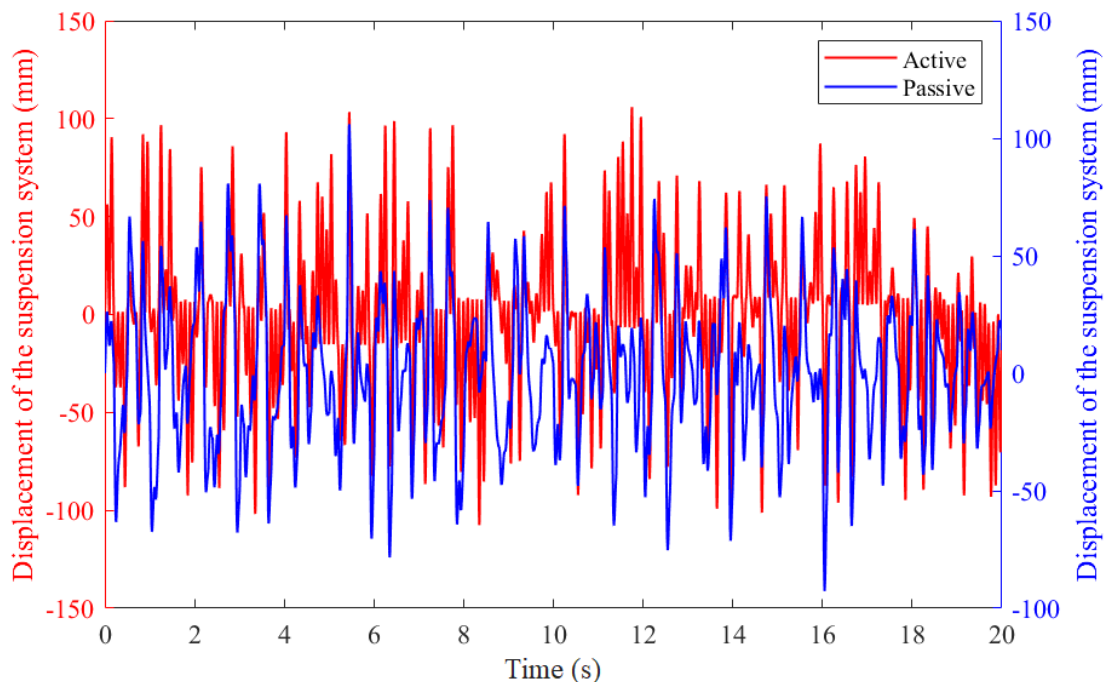

Fig. 10. Displacement of the suspension system

Case 2: Random function

In this case, the bump on the road is a random function. The change of the displacement of the sprung mass is subject to the change of the road profile. If the vehicle uses the passive suspension system, this value will change continuously with a quite large amplitude, from -58 mm until 69 mm. However, the displacement of the sprung mass

will be kept stable if the active suspension system is used with the designed sliding mode controller (Fig. 9). This value only fluctuates with a very small amplitude, about 2.8×10^{-7} mm.

In case 2, the displacement of the suspension system using a controller and without a controller is equivalent. The difference in value is not too great (Fig. 10).

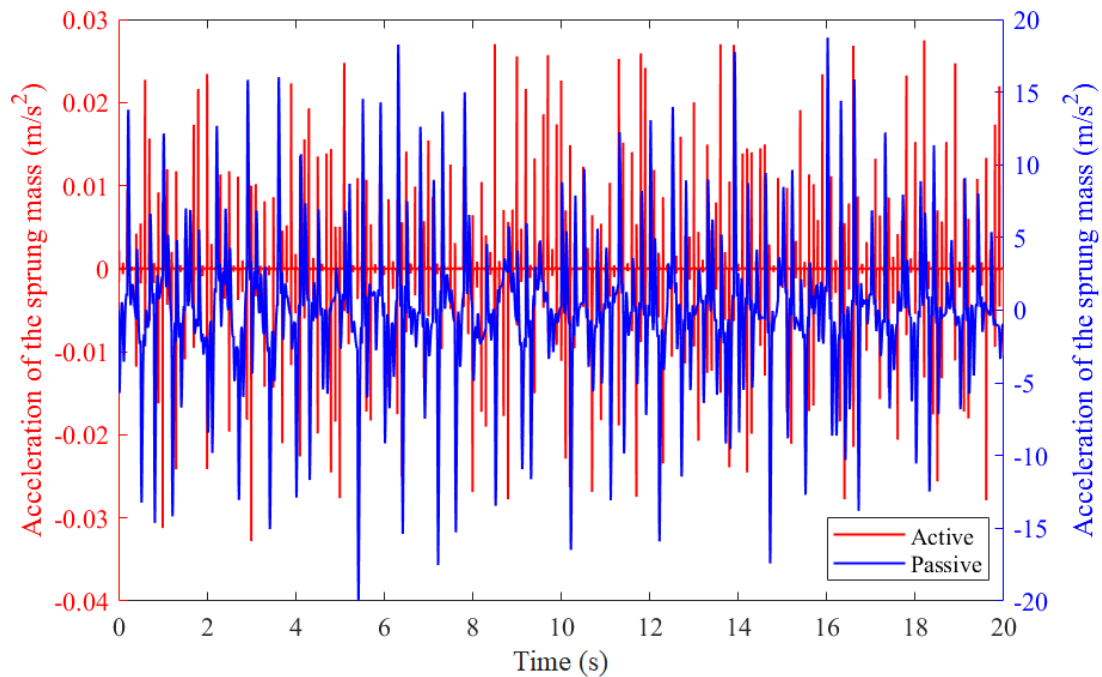

Fig. 11. Acceleration of the sprung mass (m/s²)

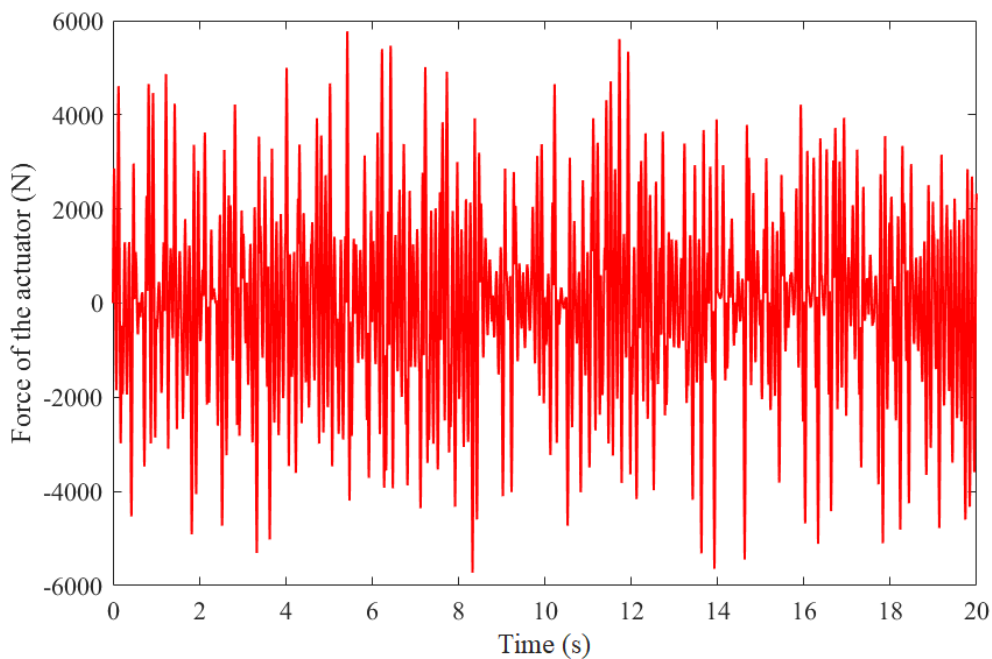

Fig. 12. Force of the actuator

The acceleration of the sprung mass has been significantly reduced when using the active suspension system with the designed sliding mode controller (Fig. 11). Its maximum value does not exceed 0.03 m/s². Meanwhile, the value of acceleration when the vehicle is equipped with the passive suspension system can be up to nearly 20 m/s². This is a very large number, and this can directly affect the

comfort of the smoothness of the passengers.

The control force of the actuator also changes continuously according to the road's profile (Fig. 12). Because the variation is continuous, these values are larger than those of case 1. In general, the stability range of this value will be less than 2000 (N).

4. CONCLUSION

The suspension system has a great influence on the comfort and safety of the vehicle on the road. The vehicle's vibrations can cause discomfort for passengers. In order to enhance stability and comfort, the suspension system of the vehicle needs to be improved. Today, on modern vehicles, the active suspension system is used. This suspension system uses a hydraulic actuator to generate force, which is applied to the sprung mass and the unsprung mass. Therefore, the comfort and stability of the vehicle can be improved.

There are many methods used to control the performance of the active suspension system. In this article, the sliding mode control method is used. The results of the study have shown that:

- When the vehicle uses the active suspension system controlled by the sliding mode controller, the value of the displacement of the sprung mass is almost unchanged (its value is very small). If the vehicle uses the conventional passive suspension system, this value changes according to the bump on the road.
- The acceleration of the sprung mass when the vehicle uses the active suspension system, which is controlled by the sliding mode controller is much smaller than the passive suspension system.
- The displacement of the suspension system when the vehicle is equipped with the active suspension system will be greater than the value of the remaining system. This is completely compatible and does not affect the comfort of the vehicle when moving.
- The sliding mode controller is very robust and stable against the change of external factors. However, its design and control process are much more complicated than that of other linear controllers.

In order to accurately evaluate the effectiveness of this controller, experiments in the future need to be conducted.

NOMENCLATURE

- ξ: Displacement of the unsprung mass (m)
 C: Coefficient of the damper (Ns/m)
 F_C: Force of the damper (N)
 F_K: Force of the spring (N)
 F_{KT}: Force of the tire (N)
 F_S: Force of the actuator (N)
 h: Bump on the road (m)
 K: Coefficient of the spring (N/m)
 K_T: Coefficient of the tire (N/m)
 M: Sprung mass (kg)
 m: Unsprung mass (kg)
 z: Displacement of the sprung mass (m)

REFERENCES

- Anh, N.T. 2020. Control ac active suspension system by using PID and LQR controller. *International Journal of Mechanical and Production Engineering Research and Development*, 10, 7003–7012.
- Avesh, M., Srivastava, R. 2012. Modeling simulation and control of active suspension system in matlab Simulink environment. *Proceedings of the Students Conference on Engineering and Systems*, Pradesh, 1–6.
- Bai, R., Guo, D. 2018. Sliding mode control of the active suspension system with the dynamics of a hydraulic actuator. *Complexity*, 5907208.
- Bello, M.M., Shafie, A.A., Khan, R. 2015. Active vehicle suspension using full state feedback controller. *Advanced Materials Research*, 1115, 440–445.
- Deshpande, V.S., Bhaskara, M., Phadke, S.B. 2012. Sliding mode control of active suspension system using a disturbance observer. *Proceedings of the 12th International Workshop on Variable Structure Systems*, Maharashtra, 70–75.
- Elmadany, M.M. 2012. Control and evaluation of slow active suspensions with preview for a full car. *Mathematical Problems in Engineering*, 375080.
- Fu, Z.-J., Li, B., Ning, X.-B., Xie, W.-D. 2017. Online adaptive optimal control of vehicle active suspension system using single network approximate dynamic programming. *Mathematical Problems in Engineering*, 4575926.
- Kaleemullah, M., Faris, W., Ghazaly, N.M. 2019. Analysis of active suspension control policies for vehicle using robust controllers. *International Journal of Advanced Science and Technology*, 28, 836–855.
- Konieczny, L., Burdzik, R. 2017. Modern suspension systems for automotive vehicles and their test methods. *Journal of Vibroengineering*, 14, 233–237.
- Lee, J., Oh, K., Yi, K. 2020. A novel approach to design and control of an active suspension using linear pump control based hydraulic system. *Journal of Automobile Engineering*, 234, 1224–1248.
- Li, W., Du, H., Ning, D., Li, W. 2019. Robust adaptive sliding mode PI control for active vehicle seat suspension systems. *Proceedings of the Chinese Control and Decision Conference (CCDC)*, China, 5403–5408.
- Lin, B., Su, X., Li, X. 2019. Fuzzy sliding mode control for active suspension system with proportional differential sliding mode observer. *Asian Journal of Control*, 21, 1–13.
- Lin, J., Lian, R.-J., Huang, C.-N., Sie, W.-T. 2009. Enhanced fuzzy sliding mode controller for active suspension systems. *Mechatronics*, 19, 1178–1190.
- Liu, Y.-J., Zeng, Q., Tong, S., Chen, C.L.P., Liu, L. 2019. Adaptive neural network control for Active Suspension Systems with Time Varying Vertical displacement and speed constraints. *Transaction on Industrial Electronics*, 66, 9458–9466.

- Marcu, S., Popa, D., Stănescu, N.D., Pandrea, N. 2017. Model for the study of active suspension. IOP Conference Series: Materials Science and Engineering, 012032.
- Maurya, V.K., Bhangal, N.S. 2018. Optimal control of vehicle active suspension system. Journal of Automation and Control Engineering, 6, 22–26.
- Na, J., Huang, Y., Pei, Q., Wu, X., Gao, G., Li, G. 2020. Active suspension control of full-car systems without function approximation. Transactions on Mechatronics, 25, 779–791.
- Na, J., Huang, Y., Wu, X., Su, S.F., Li, G. 2020. Adaptive finite-time fuzzy control of nonlinear active suspension systems with input delay. IEEE Transaction on Cybernetics, 50, 2639–2650.
- Nagarkar, M.P., Vikhe, G.J., Borole, K.R., Nandedkar, V.M. 2011. Active control of quarter car suspension system using linear quadratic regulator. International Journal of Automotive and Mechanical Engineering, 3, 364–372.
- Palanisamy, S., Karuppan, S. 2016. Fuzzy control of active suspension system. Journal of Vibroengineering, 18, 3197–3204.
- Pang, H., Chen, Y., Chen, J.N., Liu, X. 2017. Design of LQG controller for active suspension without considering road input signals. Shock and Vibration, 6573567.
- Riduan, A.F.M., Tamaldin, N., Sudrajat, A., Ahmad, F. 2018. Review on active suspension system. SHS Web Conference, 49, 02008.
- Rizvi, S.M.H., Abid, M., Khan, A.Q., Satti, S.G., Latif, J. 2018. H_∞ control of 8 degrees of freedom vehicle active suspension system. Journal of King Saud University-Engineering Science, 30, 161–169.
- Sam, Y.M., Hudha, K., Osman, J.H.S. 2007. Proportional-integral sliding mode control of a hydraulically actuated active suspension system: Force tracking and disturbance rejection control on non-linear quarter car model. International Journal of Vehicle Systems Modelling and Testing, 2, 391–410.
- Shafie, A.A., Bello, M.M., Khan, R.M. 2015. Active vehicle suspension control using electro-hydraulic actuator on rough road terrain. Journal of Advanced Research in Applied Mechanics, 9, 15–30.
- Soh, M., Jang, H., Park, J., Sohn, Y., Park, K. 2018. Development of preview active suspension control system and performance limit analysis by trajectory optimization. International Journal of Automotive Technology, 19, 1001–1012.
- Soleymani, M., Montazeri-Gh, M., Amiryan, R. 2012. Adaptive fuzzy controller for vehicle active suspension system based on traffic conditions. Scientia Iranica, 19, 443–453.
- Sun, Y., Zhao, L., Xiang, W. 2013. A fuzzy logic controller for vehicle active suspension systems. Advanced Materials Research, 805, 1645–1649.
- Tamburrano, P., Plummer, A.R., Distaso, E. 2019. A review of electro-hydraulic servo valve research and development. International Journal of Fluid Power, 20, 53–98.
- Turkkan, M., Yagiz, N. 2013. Fuzzy logic control for active bus suspension system. IOP Conference Series: International Conference on Mathematical Modelling in Physical Sciences, 410, 012006.
- Wei, S., Su, X. 2020. Sliding mode control design for active suspension systems using quantum particle swarm optimization. International Journal of Vehicle Design, 81, 93–114.
- Williams, D.E., Haddad, W.M. 1997. Active suspension control to improve vehicle ride and handling. Vehicle System Dynamics, 28, 1–14.
- Xiao, H., Chen, W., Zhou, H., Zu, J.W. 2009. Integrated vehicle dynamics control through coordinating electronic stability program and active suspension system. Proceedings of the International Conference on Mechatronics and Automation, Changchun, 1150–1155.
- Xue, X.D., Cheng, K.W.E., Zhang, Z., Lin, J.K. 2011. Study of art of automotive active suspensions. 4th International Conference on Power Electronics Systems and Applications, Hong Kong, 1–7.
- Youness, S.F., Lobusov, E.C. 2019. Networked control for active suspension system. Procedia Computer Science, 150, 123–130.