

Comprehensive exergy analysis of thermal management of cabin, battery and motor in electric vehicles

Sreekanth M^{1,2}, Feroskhan M^{2*}, Gobinath N², Govindarajan Lakshmana Rao³, Nazaruddin Sinaga⁴

¹ Electric Vehicle Incubation, Testing and Research Center, Vellore Institute of Technology Chennai, Vandalur-Kelambakam Road, Chennai 600127, Tamil Nadu, India

² School of Mechanical Engineering, Vellore Institute of Technology Chennai, Vandalur-Kelambakam Road, Chennai 600127, Tamil Nadu, India

³ University of Technology and Applied Sciences Suhar, Sultanate of Oman

⁴ Mechanical Engineering Department, Engineering faculty of Diponegoro University, Semarang, Indonesia

ABSTRACT

The world is aiming to shift to electric vehicles by year 2030 and one of the hurdles in the path is thermal management in the battery, motor and cabin. Even though there are several cooling methods available, their choice for a particular application may not be thermodynamically efficient. This study aims to thermodynamically evaluate the performance of popular cooling methods. A simulation and second law analysis of three different thermal management schemes meant to be applicable to electric vehicles has been presented in this paper. For the first time, the requirement of the passenger cabin, battery as well as motor cooling has been included in the study. The study is conducted aiming at a typical passenger car to be operating in tropical conditions with a lithium-ion battery capacity of 30 kWh and motor power of about 96 kW. Air cooling (Scheme 1), and its combinations using refrigerant (Scheme 2) as well as ethylene glycol (Scheme 3) are considered to evaluate the performance of the thermal management using the first and second laws of thermodynamics. The performance also is evaluated using two different refrigerants namely R1234yf and R134a. The models are formulated using a flow sheeting software package and several thermodynamic properties are evaluated and presented. The energetic and exergetic Coefficient of Performance (CoP) is found to be maximum for the scheme 1 while the exergy destruction is maximum for the motor in schemes 2 and 3. Among the major components, the condenser has the least amount of exergy destruction. Overall, most of the exergy is destroyed in scheme 1 while that in schemes 2 and 3 is almost identical.

Keywords: Battery cooling, Electric vehicle thermal management, Exergy analysis, Motor cooling.

OPEN ACCESS

Received: November 30, 2021

Accepted: May 8, 2022

Corresponding Author:
Feroskhan M
feroskhan.m@vit.ac.in

 **Copyright:** The Author(s). This is an open access article distributed under the terms of the [Creative Commons Attribution License \(CC BY 4.0\)](https://creativecommons.org/licenses/by/4.0/), which permits unrestricted distribution provided the original author and source are cited.

Publisher:
[Chaoyang University of Technology](https://www.ijase.in/)
ISSN: 1727-2394 (Print)
ISSN: 1727-7841 (Online)

1. INTRODUCTION

The world is fast moving towards non-fossil fuel forms of energy in order to reduce pollution and greenhouse gas emissions. Even though the complete shift might take at least half a century, immediate steps to reduce local concentration of pollutants need to be taken. It is known that automobiles cause pollution in urban areas more than in rural areas and the victims are both plant as well as human life (Iqbal et al., 2015) To reduce the damage to various life forms, electric vehicles (EVs) are being advocated for replacing internal combustion engine vehicles, especially in urban areas where the

population is highly concentrated. Another advantage of the electric vehicles is their high efficiency of operation between battery and wheels especially when compared to IC engines (Suh and Cho, 2017). Several countries have imposed a target of year 2030 to convert most of their automobiles to electricity based vehicles (Jochem et al., 2015).

However, there are several unresolved issues which pose a challenge to achieve this target. Development of compact and long life battery technology which is light and cheap is one of them. Vehicle charging infrastructure is still under developed in most part of the world (Das et al., 2020). The transmission systems as well as the motors are quite well established and efficient. A major limitation that could hinder the development of EVs is the thermal management, especially that pertaining to the battery (Das et al., 2020) and motor (Tikadar et al., 2021). Poor battery thermal management could lead to thermal runaway or poor battery life (Das et al., 2020) while poor motor thermal management could damage the magnets and hamper the magnetic field development (Tikadar et al., 2021). To make the problem even worse, the thermal limits of the battery, especially the now popular Lithium ion battery is quite narrow and lies in between 15°C and 50°C. For the electric motors, the thermal limits can be extended up to 80°C. Technologies and cooling methodologies are being investigated keeping in mind the limited space and weight of the EV, when if not adhered to would reduce the vehicle's range. Various cooling methods include employing micro-channels for coolant flow, phase change materials, dielectric liquids, jet impingement etc. (Gronwald and Kem, 2021). These studies are carried out experimentally as well as computationally using computational fluid dynamics methods as well as analytical methods using resistance network principles.

There are a few studies carried out to understand the cooling effectiveness at the system level (Sreekanth and Feroskhan, 2021) especially for batteries. Hamut et al. (2012a) have considered three different cooling methods as well as an analytical model to compute the temperature distribution in the EV battery. Hamut et al. (2014a) have considered a range extended EV and studied its battery cooling performance through CoP, exergy efficiency and environmental impact. In another study, they conducted exergo-economic as well as life cycle study of batteries of EVs (Hamut et al., 2014a). Hamut et al. (2014b) also studied the exergo-economic as well as environmental impact and optimization studies to minimize the cost and maximize exergy efficiency. In a later study, they studied the influence of operational conditions of the cooling system components on the 2nd law parameters like exergy, destruction etc. (Hamut et al., 2014c). Javani et al. (2014) considered phase change materials for battery cooling and conducted optimization studies with respect to cost and efficiency. Zhang et al. (2014) included psychrometric conditions in their study of batteries. Tian et al. (2019) proposed the recovery of motor heat for application in heat pump systems

in cold climate. While the above mentioned studies considered only the battery, Zhang et al. (2020) included the cabin cooling also in their study and involved cooling/heating/demisting modes to cover a wide range of weather conditions. Tang et al. (2020) have conducted experiments on cabin/battery cooling studies at various operating conditions and they also conducted exergy analysis to identify locations of maximum exergy destruction.

From the open literature, it can be found that several thermal management methods (mostly for cooling) have been proposed. These methods range from simple air cooling (which is also the most preferred one), refrigeration methods, using phase change materials, dielectric cooling methods etc. for batteries. For motors, air cooling, jacket cooling, oil impingement methods etc. are used. Few studies also considered using heat pipes and thermoelectric cooling techniques. The reported studies either focused on the battery or the motor. Few studies were reported on the cabin cooling but from the human comfort view point alone. All three components have different thermal requirements. The cabin needs to be maintained at 25°C, the battery (lithium ion) needs to be inside the range of 10°C - 45°C, while the motor should not exceed 75°C. Deviation in any one of these can jeopardize the electric vehicle performance and can even lead to human fatality.

From the above-mentioned literature review, it can be seen that there has been no study which included cabin, battery as well as motor thermal management together. Such a study is important as all the three components will be simultaneously operational in a moving EV. Also, thermal load on the cabin can influence the discharge rate of battery and hence its heat generation rate. Therefore, this study aims to conduct a comprehensive evaluation of the thermal management of cabin, battery and motor of an EV based on the second law of thermodynamics. An exergy analysis will be carried out during the study. Three different cooling schemes are considered: (i) air cooling, (ii) refrigerant cooling and (iii) refrigerant and coolant. The refrigerant used is 2,3,3,3-Tetrafluoropropene commonly known as R1234yf which has a lower global warming potential (< 1) compared to the commonly used 1,1,1,2-Tetrafluoroethane, R134a (~1,430). Both these refrigerants have been considered for comparison. The coolant in the battery is taken to be ethylene glycol.

2. COOLING MODES OF ELECTRIC VEHICLE

The heat loads offered by the cabin, battery and motor have been chosen based on tropical climate conditions. The cabin heat load is taken as 5 kW (1.5 tons) as proposed by (Fayazbakhsh and Bahrami, 2013), while the heat to be removed from the battery and motor are 5 kW (Tian and Gu, 2019; Arora and Kapoor, 2019) and 10 kW (Gronwald and Kem, 2021) respectively. Several cooling methods like

using phase change materials (Bellettre et al., 1997), oil jet impingement (Davin et al., 2015), using heat pipes (Putra and Ariantara, 2017; Huang et al., 2018; Huang et al., 2019) have been proposed for electric motors. Similarly, air cooling, liquid cooling, phase change materials, heat pipe based cooling, refrigeration based cooling, hybrid cooling, hydrogels based cooling system, using vortex generators, thermoelectric coolers were studied for battery cooling as reviewed by Tete et al. (2021) and Zhang et al. (2022). Another hybrid cooling method involving vapour compression and absorption was proposed by Pan et al. (2021) Studies were also carried out to meet the battery heating as well as cooling requirements depending on the ambient conditions.

Although, there are several different cooling methods have been studied, many of them have not been commercialized on electric vehicles either due to their inability in meeting the heat load (eg. Thermoelectric method) or due to lack of compactness (eg. phase change materials). The most desirable method is still the ambient air cooling method as it eliminates the need for carrying any coolant and the associated pump, pipes, valves and their controls. However, due to its low cooling capacity due to poor thermal conductivity, air cooling is clubbed with refrigerant and this configuration and technology are already available. The existing cabin refrigeration system

alone needs to be scaled up to meet the cooling requirements of the battery and motor. This is the most convenient cooling method as on date and hence this method is considered in this study.

Three schemes of cooling have been proposed. The first scheme (Fig. 1) is the simplest one which involves air as the cooling medium. Air passes over the evaporator of the vapour compression cycle and the cool air is first passed through the cabin for maintaining comfort conditions. Then it is passed through the battery's cooling channels. A parallel line from the evaporator exit is drawn and is passed through the motor cooling channels. The second scheme (Fig. 2) is an extension of the first one but the battery and motor cooling is carried out by passing the refrigerant through their respective cooling channels while the cabin is cooled using the air which is cooled in the evaporator. The third scheme (Fig. 3) is an extension of the second scheme while it includes a third fluid, the coolant namely ethylene glycol (EG). It involves two additional heat exchangers between the refrigerant and the coolant passing through the battery channels and between the refrigerant and coolant passing through the motor cooling channels. In Fig. 1, all the components needing cooling have been clubbed together as they are cooled by air alone. The components have been separated in Figs. 2 and 3.

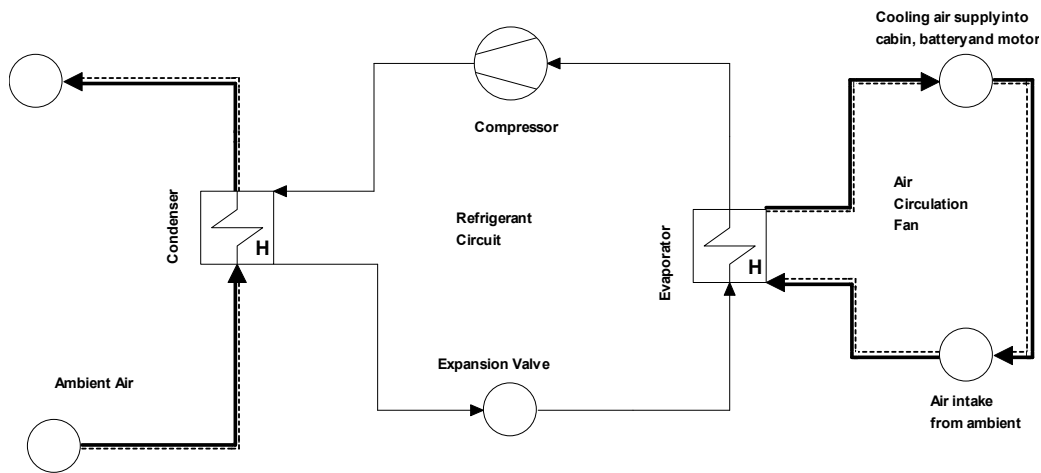

Fig. 1. Thermal management scheme 1 involving air and refrigerant with cool air passing through cabin, battery and motor

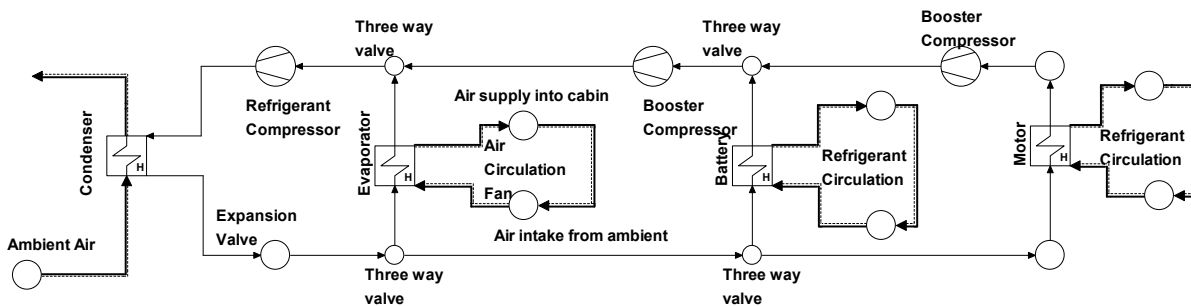

Fig. 2. Thermal management scheme 2 involving air and refrigerant

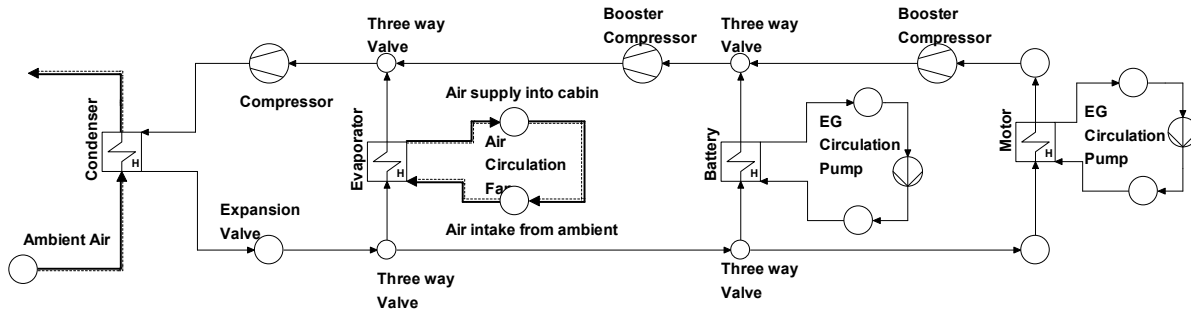

Fig. 3. Thermal management scheme 3 involving air, refrigerant and ethylene glycol coolant

3. MODEL FORMULATION AND ANALYSIS

The three cooling systems have been modelled in a flow-sheeting software Cycle-Tempo. The software needs the components to be loaded and connected by the appropriate fluid pipes. In the present work, pipes carry air, refrigerant and ethylene glycol. The software computes the required fluid properties using FluidProp (for air and ethylene glycol) and REFPROP (for R1234yf). On supplying necessary and sufficient inputs, the software formulates the necessary mass, energy, exergy, entropy balance equations and solves them simultaneously in the back ground. Table 1 gives the details of the conditions for which the model is formulated:

Table 1. Model parameters

Parameter	Magnitude
Electric Car Model	Tata Nexon EV
Ambient Pressure	1.01 bar
Ambient Temperature	35°C
Dead state conditions	1.01 bar, 25°C
Refrigerant	R1234yf
Coolant	Ethylene Glycol (EG), used in scheme 3
Refrigeration System	Vapour compression
Electric Motor efficiency	90% (used to compute heat generated)
Electric Motor rated power	96 kW
Battery type	Lithium-ion
Battery Capacity	30 kWh
Cabin heat load	~1.5 tons (5 kW), includes heat generated by 5 occupants (Arora and Kapoor, 2019)
Isentropic efficiency of compressor	81-85%
Isentropic efficiency of pump	90%
Mechanical efficiency of compressor and pump	90%
Main compressor pressure ratio	7.85
Cabin Temperature range	25-30°C
Battery temperature range	10-60°C
Motor temperature range	25-75°C

The following assumptions are made in the model formulation:

1. The system operates at steady state conditions.
2. At the evaporator and condenser exits in the vapour compression system, the refrigerant is dry saturated and saturated liquid respectively.
3. Changes in the kinetic and potential energy is neglected throughout.
4. Pressure drop in the flow lines has been taken as 0.1 bar.
5. The following equations are framed and solved for all the components in the steady flow system:

Mass Balance:

$$\sum_{in} \dot{m} = \sum_{out} \dot{m} \tag{1}$$

Energy Balance:

$$\sum_{in} \dot{E} = \sum_{out} \dot{E} \tag{2}$$

For multiple streams:

$$\dot{Q} - \dot{W} = \sum_{out} \dot{m}h - \sum_{in} \dot{m}h \tag{3}$$

For single stream:

$$\dot{Q} - \dot{W} = \dot{m}[h_2 - h_1] \tag{4}$$

Exergy Balance:

$$\dot{X}_{in} - \dot{X}_{out} - \dot{X}_{destroyed} = 0 \tag{5}$$

Rate of net exergy transfer by heat, work, and mass

$$\dot{X}_{heat} = \left(1 - \frac{T_0}{T}\right) \dot{Q} \tag{6}$$

$$\dot{X}_{work} = \dot{W}_{useful} \tag{7}$$

$$\dot{X}_{mass} = \dot{m}\psi \tag{8}$$

$$\psi = (h - h_0) - T_0(s - s_0) \tag{9}$$

$$\dot{X}_{destroyed} = T_0 \dot{S}_{gen} \tag{10}$$

$$CoP_{En} = \frac{\text{Heat Removed}}{\text{Work Input}} \tag{11}$$

$$CoP_{Ex} = \frac{\text{Exergy of the heat removed}}{\text{Work Input}} \tag{12}$$

4. RESULTS AND DISCUSSION

The three cooling modes have been simulated with the dead state taken as 25°C and 1.01 bar. Evaluation results of schemes 1, 2, and 3 are shown in Figs. 4, 5, and 6 respectively using R1234yf as the refrigerant in the vapour compression system. In scheme 1, the inlet temperature of air is taken as 75°C, corresponding to the needs of motor and is also the highest value. This air needs to be cooled to 25°C, which meets the temperature needs of the cabin as well as battery. In other schemes, the cabin, battery and motor have been treated separately and their individual thermal needs have been considered. In Fig. 6 (of scheme 3), ethylene glycol is employed as the coolant that is used to evacuate the heat from the motor. Similar results have been obtained using R134a but are not shown here for brevity. From Fig. 4, which represents the scheme 1, it can be seen that the evaporator is evacuating 20 kW of heat as required by the three components (cabin, battery and motor). So, this heat exchanger is burdened with high heat duty when compared to schemes 2 and 3 (shown in Figs. 5 and 6) where the heat duty is distributed in individual heat exchangers. In Figs. 5 and 6, the cabin and battery heat load is seen as 5 kW each while the motor heat load is 10 kW. Also, from Figs. 4, 5 and 6, one can see various parameters like pressure, temperature, enthalpy and flow rate at different points in the system. The exergy values too are shown at few select points. The exergies include thermo-mechanical exergies alone and not chemical exergy. The mass flowrates of different fluids

are presented in Table 2. It can be observed that the flow rates for R134a are in general lower compared to those of R1234yf. This could result in lower pressure drops, lower pumping and compression work needed while handling R134a. The main compressor in the refrigeration system turns out to be the major consumer of power with that in scheme 1 consuming 11.19 kW while that in schemes 2 and 3 consuming 11.02 kW with R1234yf as the refrigerant. When using R134a, main compressor in scheme 1 consumed 9.34 kW, compressor in scheme 2 consumed 9.13 kW while that in scheme 3 consumed 9.14 kW. The air flow rate is 0.395 kg/s in scheme 1 while it is 0.495 kg/s in schemes 2 and 3. The ethylene glycol flow rates are equal in schemes 2 and 3 because the heat to be removed and the higher and lower temperature limits have been kept the same. The main compressor consumes most of the power while the booster compressor 1 and 2 and the pumps handling the coolant and air circulation fans consume less than 1 kW power.

Fig. 7. shows the comparison of CoP for the three schemes and two refrigerants using equations 11 and 12. The energetic CoP is greater than 1 while the exergetic CoP is less than 1. Also, the magnitudes obtained in this study compare well with those obtained by Hamut et al. (2012b). Their CoP_en was reported at around 2 while CoP_ex is less than 0.5. Exergetic CoP is a comparison with the best possible performance and understandably is less than 1. Overall, the energetic and exergetic CoP of scheme 1 turns out to be higher than that of the others. This could be due to the excess number of components in scheme 2 and 3. More the number of components, greater will be the irreversibilities brought in by them. The energetic CoP is close to 2 while exergetic CoP is close to 0.5 in most cases. Also, both CoPs are higher for R134a when compared to R1234yf. Hence, from the CoP view point, scheme 1 turns out to be the better option with CoP_ex greater than 0.5 for all schemes.

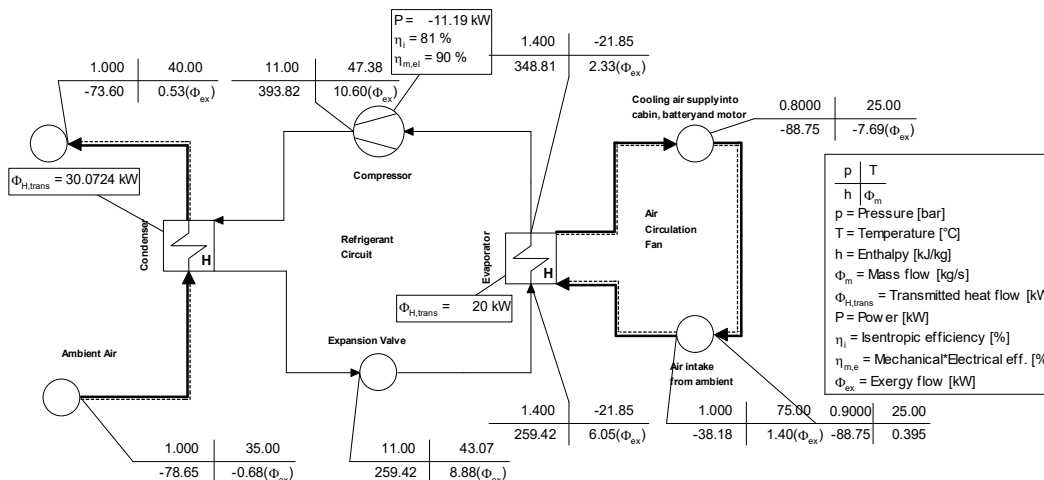

Fig. 4. Simulation results showing various parameters for cooling scheme 1 with R1234yf refrigerant

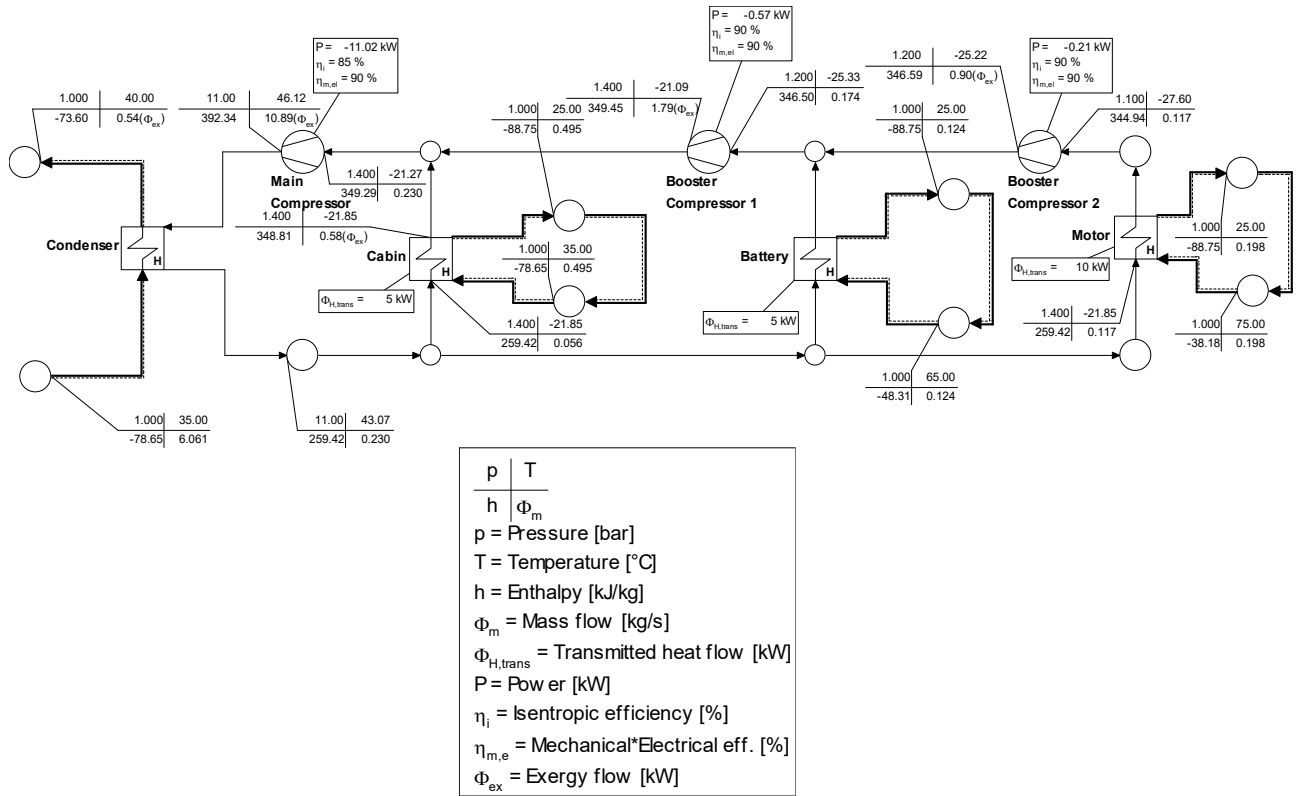

Fig. 5. Simulation results showing various parameters for cooling scheme 2 with R1234yf refrigerant

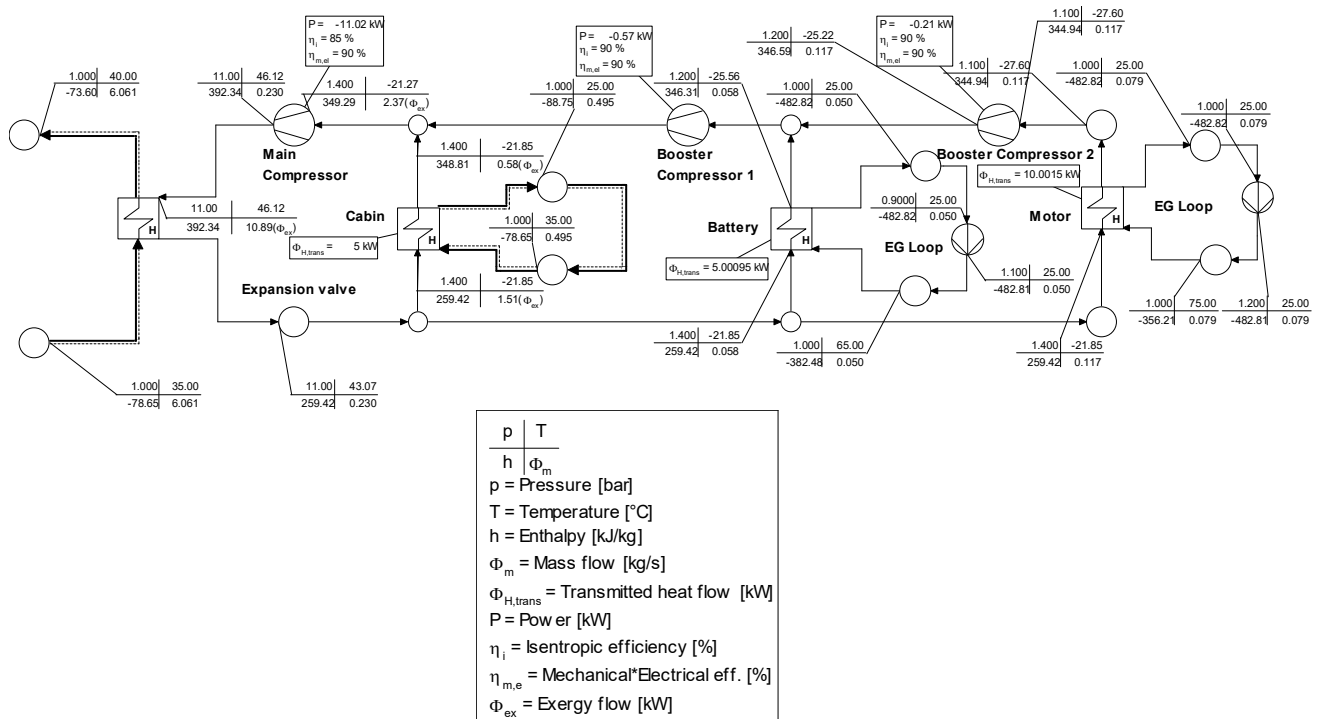

Fig. 6. Simulation results showing various parameters for cooling scheme 3 with R1234yf refrigerant

Table 2. Fluid flow rates in different cooling schemes

	Scheme 1, kg/s		Scheme 2, kg/s		Scheme 3, kg/s	
	R1234yf	R134a	R1234yf	R134a	R1234yf	R134a
Refrigerant flow rate in cabin	0.224	0.158	0.230	0.161	0.230	0.161
Refrigerant flow rate in battery	-	-	0.124	0.122	0.058	0.040
Refrigerant flow rate in motor	-	-	0.117	0.081	0.117	0.081
Air flow rate	0.395	0.395	0.495	0.495	0.495	0.495
Coolant flow rate in battery	-	-	-	-	0.050	0.050
Coolant flow rate in motor	-	-	-	-	0.079	0.079

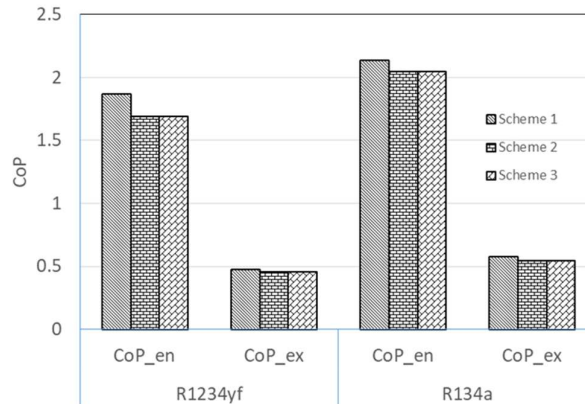

Fig. 7. The Energetic CoP (CoP_{en}) and Exergetic CoP (CoP_{ex}) for different schemes refrigerants

Fig. 8 shows the exergy destroyed (in kW, using equation 10) for the major components of scheme 1 while using different refrigerants. Firstly, it can be noted that the heat exchanging equipment representing the cabin, battery and motor have the highest amount of exergy destruction while the condenser experiences the least amount. This could be due to the large temperature difference between the refrigerant and the battery and motor. The refrigerant is at -21°C in the evaporator while the motor is at 75°C and battery is at 60°C. However, in the condenser, the refrigerant is around 40°C while the ambient is at 35°C. Hence, lower temperature difference between the hot and cold fluids exists in the condenser resulting in lower exergy destruction. This is in agreement with the principles of thermodynamics which state that irreversibilities will be higher when heat transfer takes place at higher temperature differences (Boles and Cengel, 2014; Dincer et al., 2016). It can also be seen that R134a gives a slightly lower exergy destruction compared to R1234yf.

Similar trend can be observed for schemes 2 and 3 as shown in Fig. 9. Due to the high temperature difference, motor cooling results in the highest exergy destruction while those of cabin and battery are approximately half of that of motor. In this case, expansion valve results in higher exergy destruction compared to cabin and battery and is on par with the motor. Another common observation is the lower exergy destruction in the scheme using R134a. For most cases, the exergy destruction using R134a and R1234yf differ only slightly while in the case of expansion valve, the destruction is almost half of that using R1234yf. This could be

attributed to the difference in fluid properties. Fortunately, the overall difference between the performances of both these refrigerants is very small. Also, the expansion valve demonstrates higher destruction as it carrying out almost uncontrolled expansion.

From the above results and discussion, it can be seen that scheme 1 results in better CoPs and R134a is a better refrigerant from the exergy destruction view point. Scheme 1 fares poorly when it comes to exergy destruction. Also, the exergy destruction in the heat exchangers can be reduced by decreasing the temperature difference between the cold and hot fluids. For this, a careful selection of the refrigerant/coolant would be needed, based on the range of temperatures involved.

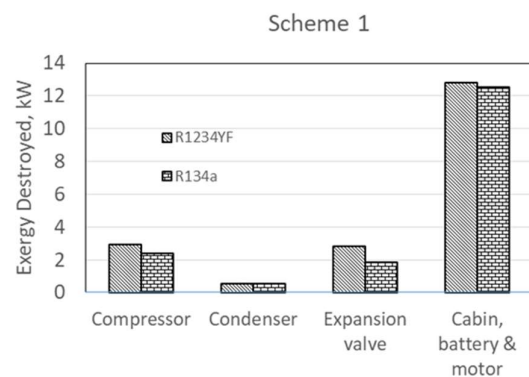

Fig. 8. Exergy destroyed in various components of cooling scheme 1

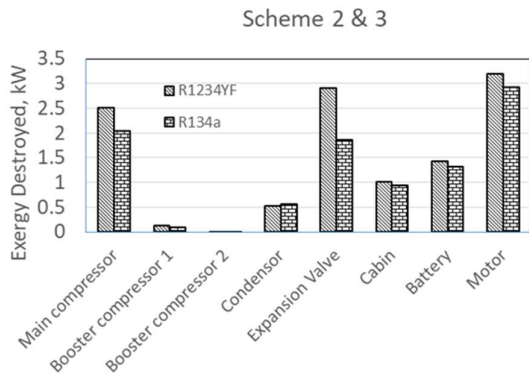

Fig. 9. Exergy destroyed in various components in schemes 2 and 3

5. CONCLUSIONS

The following major conclusions can be made from the study:

Among the three schemes studied, schemes 2 and 3 perform almost identically and are better than scheme 1 from exergy destruction view point. R134a turns out to be a better refrigerant compared to R1234yf from purely thermodynamics view point. However, R134a fares poorly from the global warming view point and hence it is being phased out. Maximum exergy destruction in scheme 1 takes place in the cabin, battery and motor and amounts to about 12 kW. The combined exergy destruction in cabin, battery and motor in schemes 2 and 3 is about 5.5 kW, which is less than half of scheme 1. Due to this, schemes 2 and 3 fare better with lower exergy destruction. Schemes 2 and 3 perform equally well and they can replace each other. Hence, wherever refrigerant costs are high, scheme 3 can be chosen for reducing the initial costs.

6. FURTHER RESEARCH

The present work has compared three different cooling schemes which are based on vapour compression refrigeration system. The work can be extended as mentioned below:

1. Other cooling methods like those using phase change materials, heat pipes, thermo-electric cooling, vapour compression-absorption etc. can be studied.
2. There are several modes of cooling methods adopted for batteries and likewise for motors. Studies can be carried out by choosing different cooling option combinations for battery and motor. Such a study would be able to suggest a thermodynamically best cooling mode combination.
3. The present study considered the case where only cooling would be needed. Such a study is relevant for tropical climate. However, there are situations where heating of battery would be necessary, especially when

the ambient temperature falls below 15°C. Studies considering heating needs where the cabin and battery need to be heated can be carried out. The refrigeration system should function as a heat pump.

4. The influence of ambient temperature on the cooling system can be studied, which would be relevant to climates with wide variations in the weather conditions.
5. The condensate obtained in the condenser is at a temperature below the ambient temperature. Possibility of utilizing it for cooling purpose can be explored.
6. Performance optimization can be studied aiming at maximizing the CoP by varying the operating conditions, primarily the pressure of the evaporator and compressor.
7. Correlations relating the number of passenger, battery type and capacity, motor rating, type of cooling scheme etc. to the performance parameters like the energetic and exergetic CoP, entropy generated and exergy destroyed can be derived.

NOMENCLATURE

Symbol	Name
CoP	Coefficient of performance
CoP _{en}	Energetic coefficient of performance
CoP _{ex}	Exergetic coefficient of performance
\dot{E}	Rate of energy transfer, kW
h	Specific enthalpy, kJ/kg
h ₀	Dead state specific enthalpy, kJ/kg
\dot{m}	Mass flow rate, kg/s
\dot{Q}	Rate of heat transfer, kW
S	Specific entropy, kJ/kg-K
S ₀	Dead state specific entropy, kJ/kg-K
S _{gen}	Entropy generated, kJ/K
T	Absolute temperature, K
T ₀	Dead state temperature, K
\dot{W}	Rate of work, kW
\dot{X}	Rate of Exergy Transfer, kW
X _{destroyed}	Exergy destroyed, kW

REFERENCES

Arora, S., Kapoor, A. 2019. Experimental study of heat generation rate during discharge of lifepo4 pouch cells of different nominal capacities and thickness. Batteries, 5, 70.

Belletre, J., Sartre, V., Biais, F., Lallemand, A. 1997. Transient state study of electric motor heating and phase change solid-liquid cooling. Applied Thermal Engineering, 17, 17–31.

Boles, M., Cengel, Y. 2014. Thermodynamics: an engineering approach. McGraw-Hill Education, New York.

Das, H.S., Rahman, M.M., Li, S., Tan, C.W. 2020. Electric vehicles standards, charging infrastructure, and impact on

- grid integration: A technological review. *Renewable and Sustainable Energy Reviews*, 120, 109618.
- Davin, T., Pellé, J., Harmand, S., Yu, R. 2015. Experimental study of oil cooling systems for electric motors. *Applied Thermal Engineering*, 75, 1–3.
- Dincer, I., Hamut, H.S., Javani, N. 2016. *Thermal management of electric vehicle battery systems* John Wiley & Sons.
- Fayazbakhsh, M.A., Bahrami, M. 2013. Comprehensive modeling of vehicle air conditioning loads using heat balance method. SAE Technical Paper.
- Gronwald, P.O., Kern, T.A. 2021. Traction motor cooling systems, a literature review and comparative study. *IEEE transactions on transportation electrification*.
- Guo, J., Jiang, F. 2021. A novel electric vehicle thermal management system based on cooling and heating of batteries by refrigerant. *Energy Conversion and Management*, 237, 114145.
- Hamut, H.S., Dincer, I., Naterer, G.F. 2012a. Performance assessment of thermal management systems for electric and hybrid electric vehicles. *International Journal of Energy Research*, 37, 1–2.
- Hamut, H.S., Dincer, I., Naterer, G.F. 2012b. Exergy analysis of a TMS (thermal management system) for range-extended EVs (electric vehicles). *Energy*, 46, 117–25.
- Hamut, H.S., Dincer, I., Naterer, G.F. 2014a. Exergo-environmental analysis of hybrid electric vehicle thermal management systems. *Journal of Cleaner Production*, 67, 187–96.
- Hamut, H.S., Dincer, I., Naterer, G.F. 2014b. Analysis and optimization of hybrid electric vehicle thermal management systems. *Journal of Power Sources*, 247, 643–54.
- Hamut, H.S., Dincer, I., Naterer, G.F. 2014c. Exergetic and energetic evaluations of hybrid electric vehicle thermal management systems. *International Journal of Exergy*, 4, 341–63.
- Huang, J.A., Naini, S.S., Wagner, J.R., Rizzo, D., Sebeck, K., Shurin, S. 2018. An integrated cooling system for hybrid electric vehicle motors: design and simulation. *SAE International Journal of Commercial Vehicles*, 11, 255–66.
- Huang, J., Naini, S.S., Miller, R., Rizzo, D., Sebeck, K., Shurin, S., Wagner, J. 2019. A hybrid electric vehicle motor cooling system—Design, model, and control. *IEEE Transactions on Vehicular Technology*, 68, 4467–78.
- Iqbal, M., Shafiq, M., Zaidi, S., Athar, M. 2015. Effect of automobile pollution on chlorophyll content of roadside urban trees. *Global Journal of Environmental Science and Management*, 1, 283–96.
- Javani, N., Dincer, I., Naterer, G.F., Yilbas, B.S. 2014. Exergy analysis and optimization of a thermal management system with phase change material for hybrid electric vehicles. *Applied Thermal Engineering*, 64, 471–82.
- Jochem, P., Babrowski, S., Fichtner, W. 2015. Assessing CO₂ emissions of electric vehicles in Germany in 2030. *Transportation Research Part A: Policy and Practice*, 78, 68–83.
- Pan, Q.W., Shan, H., Liu, H.R., Wang, R.Z. 2021. A vapor compression-adsorption thermal management system for electric vehicle: Concept and working fluid pairs. *Energy Conversion and Management*, 238, 114168.
- Putra, N., Ariantara, B. 2017. Electric motor thermal management system using L-shaped flat heat pipes. *Applied Thermal Engineering*, 126, 1156–63.
- Sreekanth, M., Feroskhan, M. 2021. A review of the exergy analysis of thermal management systems in electric vehicles. *International Journal of Engineering Technologies and Management Research*, 8, 40–5.
- Suh, N.P., Cho, D.H. 2017. Making the move: from internal combustion engines to wireless electric vehicles. In *The on-Line Electric Vehicle*. Springer, Cham, 3–15.
- Tang, X., Guo, Q., Li, M., Jiang, M. 2020. Heating performance characteristics of an electric vehicle heat pump air conditioning system based on exergy analysis. *Energies*, 13, 2868.
- Tete, P.R., Gupta, M.M., Joshi, S.S. 2021. Developments in battery thermal management systems for electric vehicles: A technical review. *Journal of Energy Storage*, 35, 102255.
- Tian, Z., Gu, B. 2019. Analyses of an integrated thermal management system for electric vehicles. *International Journal of Energy Research*, 43, 5788–802.
- Tikadar, A., Johnston, D., Kumar, N., Joshi, Y., Kumar, S. 2021. Comparison of electro-thermal performance of advanced cooling techniques for electric vehicle motors. *Applied Thermal Engineering*, 183, 116182.
- Zhang, X., Kong, X., Li, G., Li, J. 2014. Thermodynamic assessment of active cooling/heating methods for lithium-ion batteries of electric vehicles in extreme conditions. *Energy*, 64, 1092–101.
- Zhang, K., Li, M., Yang, C., Shao, Z., Wang, L. 2020. Exergy analysis of electric vehicle heat pump air conditioning system with battery thermal management system. *Journal of Thermal Science*, 29, 408–22.
- Zhang, X., Li, Z., Luo, L., Fan, Y., Du, Z. 2022. A review on thermal management of lithium-ion batteries for electric vehicles. *Energy*, 238, 121652.